

**Cryogenic 3dB 90° stripline hybrid
couplers for the 2-14 GHz band:
Design, manufacturing and
measurement.**

*I. Malo, J.D. Gallego, C. Diez, I. López, R. Amils, R.
García, G. Martínez*

IT-CDT 2016-20-C

*Centro Astronómico de Yebes
Apdo. 148 19080 Guadalajara
SPAIN
Phone: +34 949 29 03 11 ext.208
Fax: +34 949 29 00 63*



Change Record

Revision	Date	Affected Paragraphs(s)	Reason/Initiation/Remarks
A	2016-09-29	All	First Issue
B	2021-11-28	2. Measured performance	Improve information about the results
C	2021-08-03	All	Photo, mechanical and electrical interfaces, information about the measurement procedure.



TABLE OF CONTENTS

1. Introduction	4
2. Dimensions and mechanical-electrical interfaces.....	5
3. Measurements.....	5
4. References.	7

1. Introduction

The 2-14 GHz band has been established as the new standard for the VGOS (VLBI Global Observing System) stations for Geodesy observations. This ultra wide band represents an interesting challenge for several critical components of the receivers like feeds, polarizers and LNAs.

Wideband cryogenic LNAs with quite good performance in the 2-14 GHz band have been demonstrated¹, but they usually present a high input reflection in the low frequency end. As cryogenic isolators for such a wide band are not feasible, the only possible alternative to obtain a good input match is to use a balanced configuration² made up of two 3 dB 90° directional couplers (hybrids) and two LNAs.

On the other hand, the feeds which are presently used in the VGOS antennas are of the quad-ridge type and provide two orthogonal linear polarizations. A single cryogenic 90° 3dB hybrid could be used to generate the two circular polarizations (right and left handed) which have been used traditionally in VLBI to avoid parallactic angle related problems.

This report presents the measurements of a **3 dB 90° directional couplers for the 2-14 GHz band, designed and fabricated in Yebes Observatory** following the structure in [1], specially conceived to operate satisfactorily when cooled down to cryogenic temperatures³. The materials and mechanical construction have been carefully selected and the result is a very compact, reliable and low thermal mass device, capable to withstand extreme thermal cycling. The coupling and reflection characteristics show very low temperature dependence.

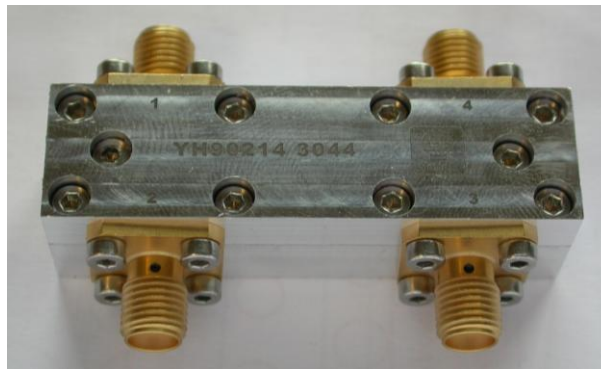

Figure 1. External view of a 2-14 GHz hybrid. Dimensions excluding connectors are 49.7x14x14 mm (XxYxZ in the picture).

¹ A. H. Akgiray, S. Weinreb, "Noise Measurements of Discrete HEMT Transistors and Application to Wideband Very Low-Noise Amplifiers", IEEE Trans. Microw. Theory Tech., vol. 61, no.9, pp. 3285 - 3297, Sep. 2013.

² R. S. Engelbrecht, K. Kurokawa, "A wideband low noise L-band balanced transistor amplifier", Proc. IEEE, vol. 53, pp. 237-247, March 1965.

³ The hybrid designed could works at any ambient temperature.

2. Dimensions and mechanical-electrical interfaces.

Figure 1 shows an outside view of a 2-14 GHz hybrid. Its external dimensions and mechanical interfaces are shown in figure 2. The hybrid chassis is made of aluminum 6082. Ten M2 threaded holes, 3.8 mm depth, are available on the bottom side of the chassis to be used for thermal anchoring.

The four ports of the hybrid are female SMA coaxial connectors.

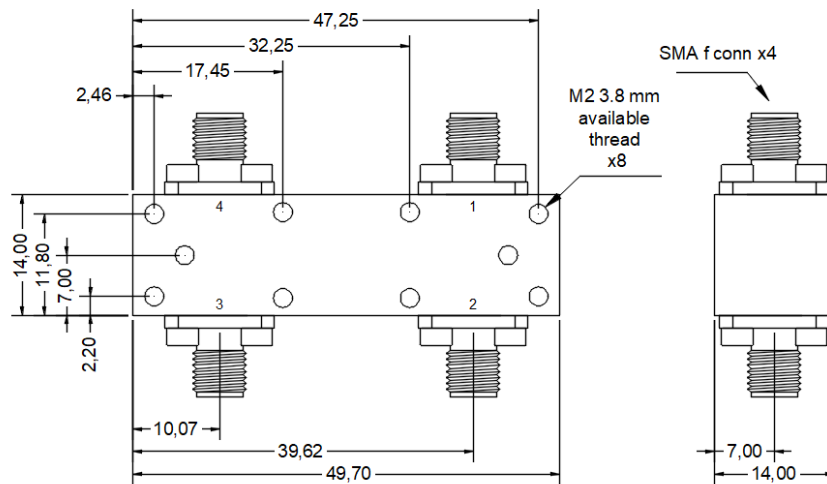

Figure 2. Dimensions of the 2-14GHz hybrid.

3. Measurements.

S-parameters of the hybrid are measured with an Agilent E8364B Vector Network Analyzer from 0.1 to 20.1 GHz at ambient temperature. For cryogenic measurements, the hybrid is cooled in a dewar with a CTI 1020 refrigerator. Two cool-down cycles are needed, one for measuring the direct path (s_{21}) and the other one for measuring the coupled path (s_{31}) of the hybrid. The isolated path (s_{41}) is not usually measured because it requires the modification of the measurement setup of the dewar and a third cool-down cycle (so it is time-consuming) but it has been proven that its value is closed to the s_{11} of the hybrid. In order to take into account of the dissipative losses of the hybrid, the average equivalent insertion loss are calculated for each unit from the s_{11} , s_{21} and s_{31} measurements, assuming s_{41} equal to s_{11} , following the equation:

$$AEIL (dB) = 10 \cdot \log_{10} (|s_{11}|^2 + |s_{12}|^2 + |s_{13}|^2 + |s_{14}|^2)$$

Measurements inside the dewar are done connecting one port of the hybrid to the stainless steel dewar transition (also connected to the VNA port 2) and the other port of the hybrid to the other transition (also connected to the VNA port 1) through a semi-flexible Cu cable. A full two port calibration is done at room temperature with the electronic calibration kit Agilent N4693-60001 (which uses a SOLT calibration (unknown thru)) inside the dewar in place of the hybrid, with the same semi-flexible cable. The stainless steel lines are supposed



to be invariant with temperature. The semi-flexible Cu cable is measured at cryogenic temperature independently and its loss is taken into account to correct s-param. Time domain gating is used to correct for the residual reflection changes in the lines. The temperature of the hybrid is carefully monitored using a Lake Shore sensor diode attached to the hybrid chassis.

The average measured performance of the last eight units made is presented in the Table 1:

Ambient temperature (K)	Amplitude unbalance (dB)	Phase unbalance (°)	Reflection 100 / 90% BW (dB)	A.E. Insertion Loss (dB)
300	0.49	4	-19 / -20	0.60
15	0.48	3	-19 / -20	0.15

Table 1. Average performance of eight hybrids randomly chosen.

The result of the measurements of one of these hybrids is shown in Table 2 and 3:

Serial Number	YH90214 3033	
Description	3dB 90° cryogenic hybrid	
Frequency Band	2 - 14 GHz	
Nominal Coupling	3 dB	
Connector	SMA female, sliding pin	
Weight (typ.)	40 g (14 oz)	
	<i>Temperature</i>	
	297 K	15 K
A. E. Insertion Loss dB (max.)	0.63 dB	0.12 dB
Return Loss (max. any port) (90% bandwidth)	-19 dB (-20 dB)	-19 dB (-20 dB)
Amplitude Unbalance (max.)	± 0.53 dB	± 0.53 dB
Phase Unbalance (max.)	± 4°	± 2°

Table 2. Performance of the hybrid with part number YH90214 3033.

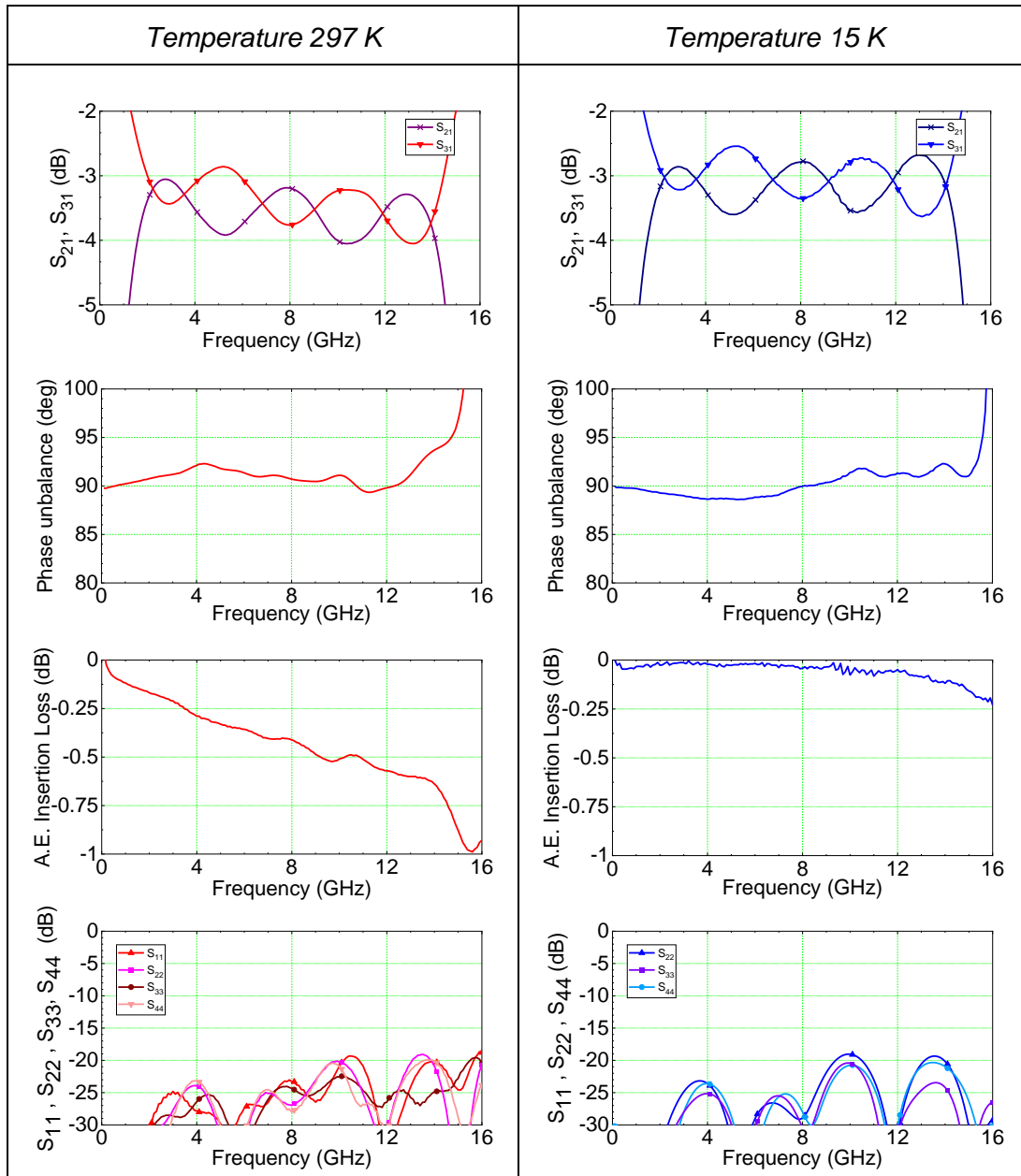

Table 3. Measurements of the hybrid with part number YH90214 3033.

4. References.

- [1] I. Malo, J.D. Gallego, C. Diez, C. Cortés, C. Briso, "Cryogenic hybrid coupler for ultra low noise Radio Astronomy receiver", 2009 IEEE MTT-S International Microwave Symposium Digest, Jun. 7-12, Boston (USA), 2009.